

foodproof® RoboPrep® 96 Operation Manual

Product No. MCH230001

Revision A, October 2024





Table of Contents

- 1. Introduction 4
 - 1.1 About RoboPrep® 96 4
 - 1.2 Technology Introduction..... 4
 - 1.3 Applications 4
 - 1.4 Waste Disposal Recommendations 4
 - 1.5 Safety Information 5
 - 1.5.1 System Compliance 5
 - 1.5.2 Safety Precautions..... 5
 - 1.5.3 Poisonous and Harmful Substances 6
- 2. Intended Use and Specifications..... 7
- 3. Basic Operating Instructions 8
- 4. Installation 11
 - 4.1 Packaging 11
 - 4.2 Labware 11
 - 4.3 Operating Conditions..... 11
 - 4.4 Initial Setup 12
 - 4.5 Transportation and Shipping of RoboPrep 96 13
 - 4.6 Functional Descriptions 14
 - 4.6.1 Main Menu 14
 - 4.6.2 Protocol Editing 14
 - 4.6.3 View Program Details 15
 - 4.6.4 LED Light 15
 - 4.6.5 UV Sterilization 15
- 5. Getting Started..... 16
 - 5.1 Preparation 16
 - 5.2 Operation with the foodproof® Magnetic Preparation Kit VI (KIT230184) 16
 - 5.2.1 Procedure 16
 - 5.2.1 Visual Representation of Procedure Steps..... 17
- 6. Cleaning and Maintenance 18
 - 6.1 Cleaning the RoboPrep 96 18
 - 6.2 RoboPrep 96 Maintenance 18



7. Troubleshooting.....	19
8. Software Error Alarm List.....	19
9. Tags	20
10. Supplementary Information	20
10.1 Liability.....	20
10.2 Trademarks	21
10.3 Copyrights	21
10.4 Contact and Support.....	21
10.5 Reference Number.....	21
11. Change Index.....	21



1. Introduction

1.1 About RoboPrep® 96

Thank you for purchasing RoboPrep 96 for your laboratory. This guide contains important information regarding the safe use of RoboPrep 96. Please read this manual carefully before operating the instrument for the first time, especially the safety information.

If you have questions about how to install or operate the instrument, please contact our technical support team (www.hygiena.com/support).

1.2 Technology Introduction

RoboPrep 96 uses the unique characteristics of magnetic-bead binding of nucleic acids under specific environmental conditions to purify target nucleic acid samples. The purification protocol includes four basic steps: sample lysis, nucleic acid binding, washing and elution. Using RoboPrep 96, most nucleic acid purification processes are done automatically inside the instrument. As a result of this automation, the reproducibility and reliability of results are increased.

During the purification process, a 96-pronged magnetic rod attached to the tip comb rack moves up and down repeatedly to mix the reagents by creating turbulence in the 96 Deep-Well Plate. When the permanent magnetic rods are inserted into the rod combs, the assembly lowers into the solution to collect the magnetic beads at the bottom of the comb. The whole assembly then moves to a different plate, and the magnetic beads are released by retracting the permanent magnetic rods. RoboPrep 96 contains an exclusive temperature control module that perfectly connects with the 96 Deep-Well Plate to enhance lysis and elution efficiency.

1.3 Applications

RoboPrep 96 purifies DNA and RNA from a variety of samples that are broadly used in molecular biology, genetic screening, sequencing, food safety and other applications.

1.4 Waste Disposal Recommendations

You play an important role in contributing to reuse and recycling, as well as other forms of recovery of electrical and electronic equipment waste. Sorting this type of waste significantly reduces potential negative effects on the environment and human health from hazardous substances in electrical and electronic equipment.

At the end of the life cycle of this product, do not dispose of the product as unsorted municipal waste, even if it is decontaminated. It is imperative to check local regulations for appropriate disposal procedures.



Warning: The above statement only applies to those in European countries concerning the Waste Electrical and Electronic Equipment (WEEE) European directive.

1.5 Safety Information

This manual uses different types of symbols to alert you to important information. Symbols and their associated information are labeled in the text where they occur and set off from surrounding paragraphs, as shown in the following examples.

Symbol and Markings	Description
	Warning: Biohazard risk.
	Warning: Risk of injury or death to users.
	Caution: Risk of damage to product.
	Warning: Burn Hazard/Hot Surface.
IMPORTANT!	Important information that helps ensure proper function of kit, reagent or instrument.

Before operating the system, it is essential that the operator read and understand the warnings, cautions and safety requirements referenced in this manual.

Warning symbols have been placed on the system to draw your attention to potential hazard areas.

1.5.1 System Compliance

The RoboPrep 96 instrument conforms to the relevant European regulations for electrical safety and electromagnetic compatibility (EMC).

- This instrument is in accordance with the following Low Voltage Directive 2014/35/EU, Electromagnetic Compatibility 2014/30/EU, EN 61326-1:2013, EN 61010-1:2010.
- It is advisable for the user to evaluate the electromagnetic environment before operating the instrument.
- The instrument is a normal indoor instrument, conforming to class I of the GB4793.1 standard.

1.5.2 Safety Precautions



Warning:

- Always use the packaging provided when shipping the instrument.
- Ensure that the instrument is installed in a well-ventilated environment in an area with minimal dust and away from wet areas, direct sunlight, electromagnetic interference and heat sources. The vents in this instrument are designed for ventilation. Do not cover them to avoid overheating.
- When multiple instruments are in use at the same time, the distance between each instrument should be more than 100 cm.
- Ensure that the power source matches the rating label on the instrument
- Turn off, remove the power cord and cover the instrument before a period of non-use or any transportation.
- The power cord is one of the emergency power supply controls. Do not place it in a hard-to-reach location.



- Power off when not in use. If the instrument will not be used for a long period of time, cover it with a cloth or plastic to protect it from dust.
- Disconnect the power cord in the following situations and contact your local representative or agent:
 - Abnormal operation, such as abnormal sound or smell during the operation
 - Liquid enters the instrument, or the instrument is sprayed with liquid
 - The instrument was dropped, and the outer shell was damaged
 - The instrument function has changed

**Caution:**

- Never attempt to modify the RoboPrep 96 system without the manufacturer's permission.
- Do not place or drop objects on the RoboPrep 96 system. Also, refrain from bumping or knocking into it.
- The RoboPrep 96 system should only be repaired by authorized representatives or agents who use original spare parts certified by Hygiena Diagnostics.
- If the equipment is used in a manner not specified by the manufacturer, the protection provided by the equipment may be impaired.

**Caution:**

- The temperature of the heating block is high. Do not touch it during operation to avoid injury.

1.5.3 *Poisonous and Harmful Substances*

**Biohazard:**

- Always wear appropriate gloves, masks, safety goggles, etc., when handling any infectious samples.
- When handling or disposing of infectious materials, follow laboratory guidelines and the law to properly incinerate, sterilize and/or disinfect infectious waste.
- When you use a third party for waste disposal, outsource this work to an operator licensed to handle medical waste subject to special control and provide them with the manifest of the medical waste along with the waste.



Warning: The ultraviolet source (254 nm) is an eye and skin hazard. Do not use the source without protection.

Note: Always wear a lab coat, gloves and safety glasses.



2. Intended Use and Specifications

This product and its accessories are for extended use in molecular biology research laboratories and diagnostic laboratories for nucleic acid extraction, purification and isolation.

2.1 Specifications

Product Specifications	
Model Name	RoboPrep 96
Instrument Type	Bench-top automated nucleic acid extractor
Sample Processing	1 – 6 samples per batch
Sample Volume	50 – 1,000 µL
Variability	CV 5 %
Consumable	2.2 mL 96 deep-well plate
Heat Block Temperature	Room temperature to 120 °C (248 °F)
Mixing Speed	10 adjustable speeds
Mixing Depth	Adjustable, based on reagent volume
Reagent Type	Magnetic beads
Control Interface	17.8-cm (7-inch) color touch panel
Extension Interface	With USB and ethernet port
Network	Extended Ethernet remote control, WiFi
Protocols	Stores 8 groups of preset protocols and 100 groups of programs
Validation	Validated for foodproof® Magnetic Preparation Kit VI
Decontamination	Built-in UV light
Fuse	5 X 20 250V 8A
Environmental Requirements: Operation	
Environmental Temperature	10 to 35 °C (50 to 95 °F)
Relative Humidity (RH)	<70%
Temperature gradient	≤12 °C/h (≤54 °F/h) (non-condensing)
Altitude during operation	≤1,600 m
Power Rating	AC 100 – 240 V, 50 Hz/60Hz, 250 VA
Environmental Requirements: Storage and Transportation	
Environmental Temperature	–20 to 55 °C (–4 to 131 °F)
Relative Humidity	<80 °C (<176 °F)
Dimension and Weight	
Dimension	550 x 620 x 483 mm (21.7 x 24.4 x 19.0 in)
Weight	25 kg (55.1 lb)
EMC	EN61326-1
Safety	EN60101-1, EN60101-2



2.1 Overall Dimensions

Unit: mm

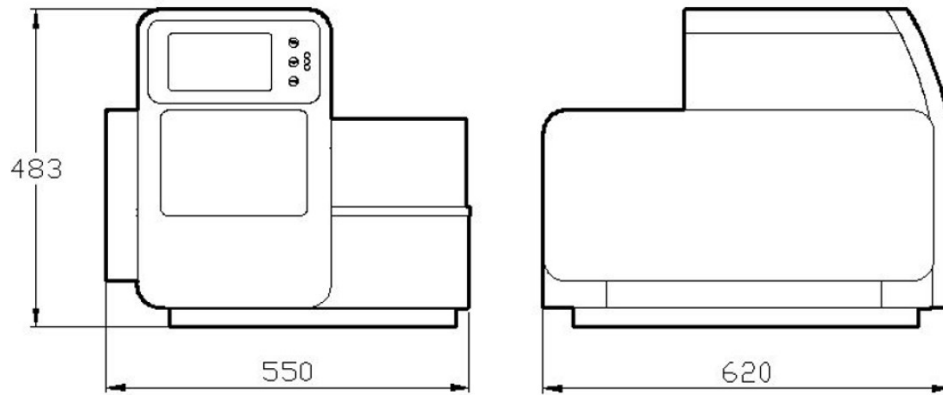

3. Basic Operating Instructions

This section introduces structures, basic operation keys, displays, and required preparations before use. Please read this section carefully before using this instrument.

3.1 Front View

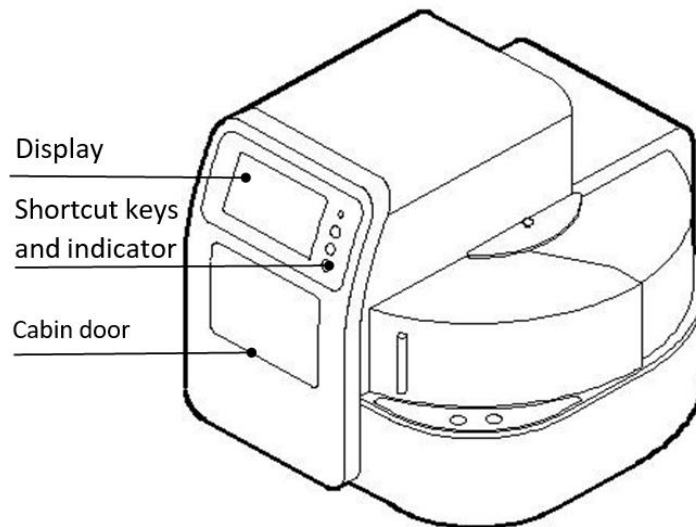

3.2 Rear View

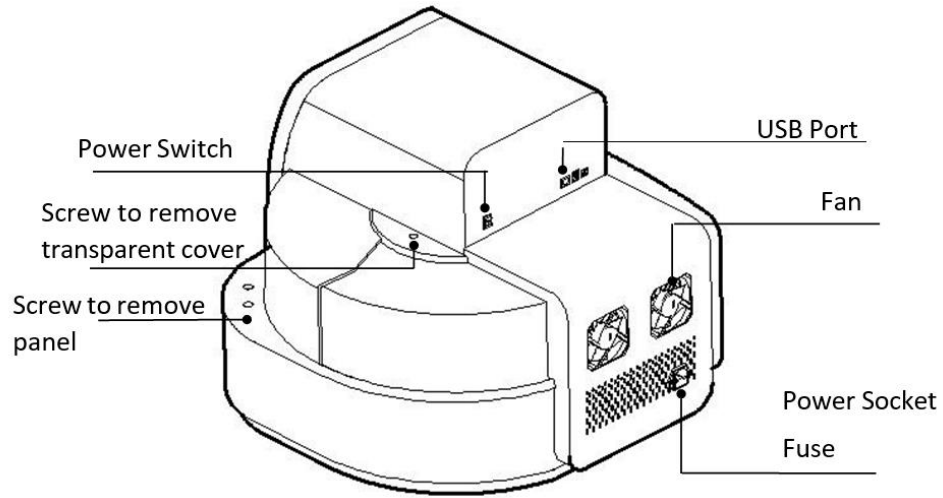

3.3 Cabin Door

The cabin door of the RoboPrep 96 can be opened for cleaning and maintenance.

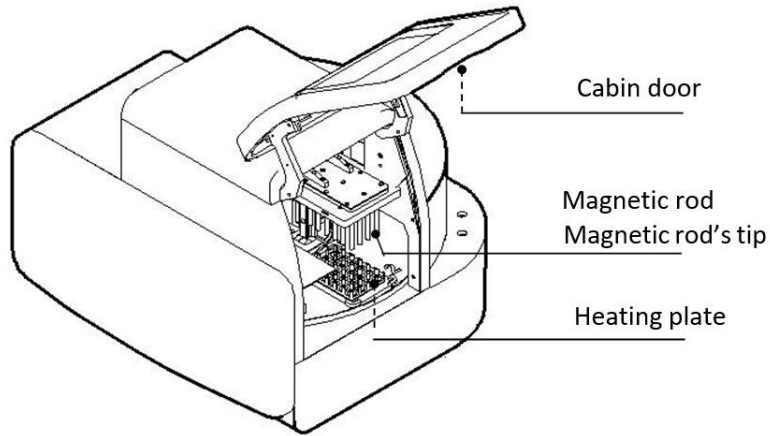

3.4 Transparent Cover

The transparent cover on the right side of the instrument is used for placing or removing consumables and reagents. The cover can be conveniently removed, similar to automatic liquid-handling workstations.

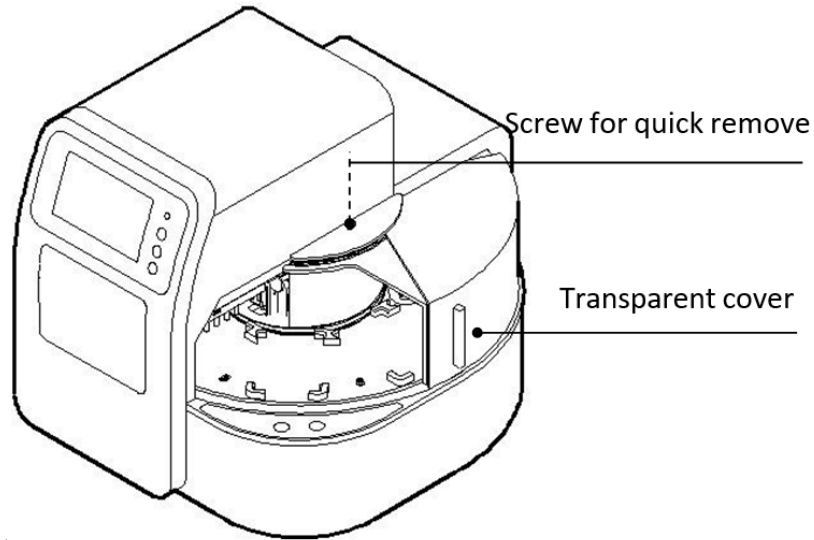

3.5 Touch Screen

Display screen: Touch screen; a mouse can also be connected for operation

TAB: Select shortcut program

RUN: Start the shortcut program and run the instrument

STOP: Stop the operation

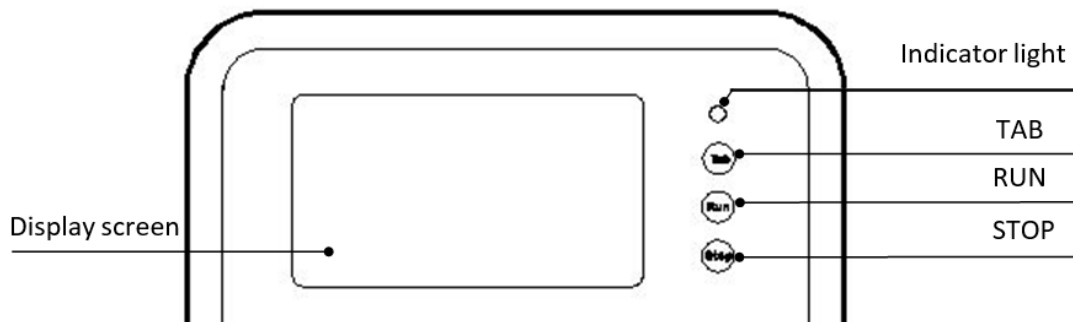



4. Installation

4.1 Packaging

Check that the following parts are included in the package. If you notice any missing part(s), contact your local representative.

- Instrument, 1X
- Power Cord, 1X
- USB Mouse, 1X
- User/Operation Instructions (USB Stick)

Ensure all components are free of damage upon receipt. If any damage is found, contact your local representative for support.

Note: Hygiena Diagnostics' warranty does not cover damage from either transportation or improper handling and operation.

4.2 Labware



60 x Tip Combs



60 x 96-Deep Well Plates, 2 mL



60 x 96-Well Plates, 0.2 mL

Note: Labware must be purchased separately. Contact your local representative for further information.

4.3 Operating Conditions

Use the RoboPrep 96 in an environment that meets the following conditions:

- In a location that is well-ventilated and not dusty.
- Ventilation space between the RoboPrep 96 and the walls.
- 100 cm between multiple RoboPrep 96 instruments.
- Near an electrical outlet.
- Between 10 and 35 °C (50 to 95 °F) and at stable temperature. (Warming a room suddenly or moving the instrument from a cold to a warm room may cause condensation inside the device that may result in abnormal extractions.)
- At a humidity of <80 % RH (non-condensing).
- On a flat and stable surface, without external vibrations.
- Away from direct sunlight. (If necessary, block sunlight by closing curtains or blinds.)
- Away from objects that generate strong magnetic fields, such as motors, transformers, televisions, audio speakers, magnets, etc. (Magnetic fields can cause the RoboPrep 96 to malfunction.)

**Caution:**

- Do not use the RoboPrep 96 in a wet environment or where it could be splashed with water, which may cause device failure, fire or electric shock.
- When moving the RoboPrep 96, first disconnect from power. A damaged power cable may cause device failure, fire, injury or electric shock.
- Do not place the RoboPrep 96 on an unstable or slanted surface or in an area subject to vibrations, which may cause injury or device failure.
- Do not use the RoboPrep 96 in direct sunlight or near a heating device, which may shorten the life of the RoboPrep 96 System or interfere with normal function.

Refer to *Section 2.1 Specifications* for additional information.

4.4 Initial Setup

Watch the RoboPrep 96 unboxing video carefully (available at www.vimeo.com/hygienatv and www.youtube.com/@hygienaTV).

IMPORTANT!

The RoboPrep 96 weighs 54 kg (119 lbs.).

The instrument should be lifted and moved by two people. Hold the instrument from two sides to remove it from the shipping box.



Caution: Improper handling of the RoboPrep 96 will lead to instrument damage.

For correct and safe use of the RoboPrep 96, install it in a location that is near an electrical outlet and has enough space for installation and operation from the main switch.

IMPORTANT!

Keep the shipping box and transport locks, as they are needed for transporting the RoboPrep 96 in the future.

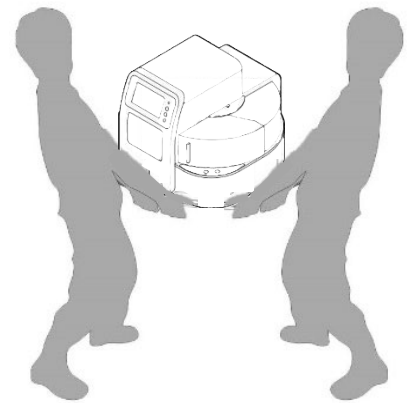

1. Open the shipping box and remove the instrument and related accessories.



- Open the cabin door and unscrew the red transportation lock screw located between the first and second plate positions.



- Cut the zip ties from the shield plate.

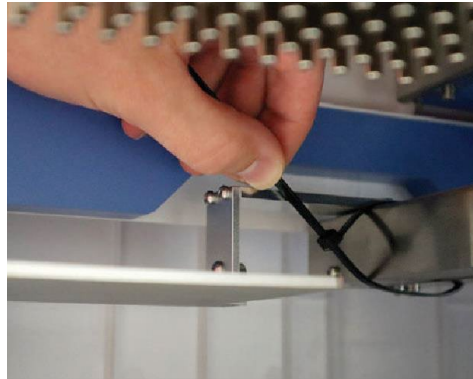

- Close the cabin door and connect the power cord to the instrument.



4.5 Transportation and Shipping of RoboPrep 96

When transporting or shipping the RoboPrep 96 to a new location, perform tasks in Section 4.4 in reverse order. Pack the RoboPrep 96 instrument and accessories in its original shipping box.



Warning: A damaged power cable may cause device failure, fire, injury or electric shock.

4.6 Functional Descriptions

4.6.1 Main Menu

Turn on the instrument and ensure the cabin door is closed before starting. A start-up 'Run Prog.' interface will appear.



4.6.2 Protocol Editing

In the system setting interface, 'Instrument,' 'Date&time,' 'Language,' 'Air ejector fan,' 'Im.&export' and 'Upgrade' can be modified.

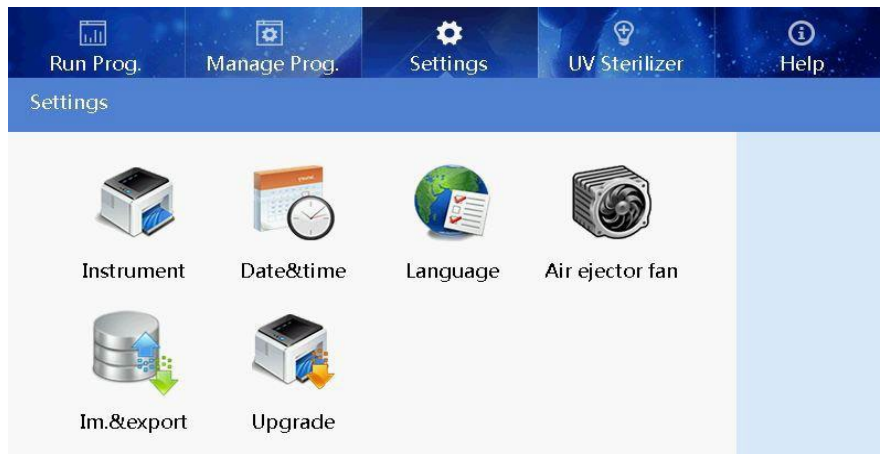

4.6.3 View Program Details

In the list or shortcut mode, select the required pre-installed program and click the 'View' button to view its parameter settings.

Users can select  in the upper right corner to switch to the graphic display. The dark blue highlighted block is the plate position, corresponding to the selected step to the left.



4.6.4 LED Light

The LED light icon is at the bottom right of the screen. Press the icon to select between on or off.

Icon	Light
	On
	Off

4.6.5 UV Sterilization

The UV disinfection interface is mainly used for activation and deactivation of the UV lamp. The time can be set by pressing the '+' or '-' button. The program can automatically determine half of the set time to sterilize the half circle of the rotary table, with a minimum of 2 min, as shown in the figure below.

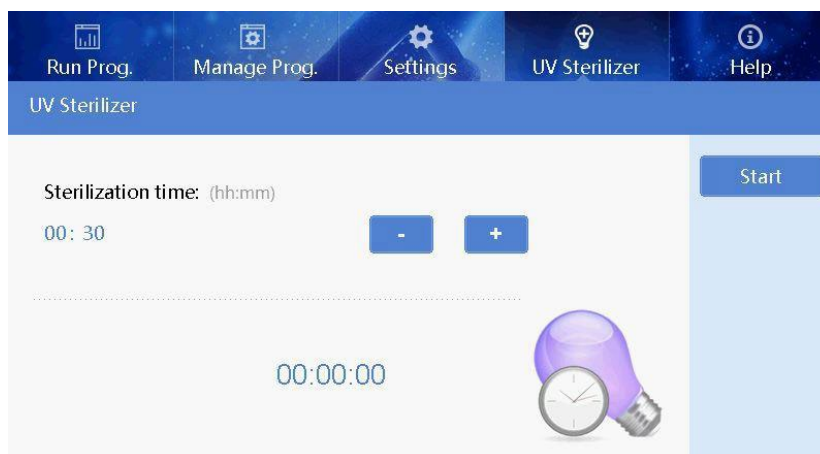

5. Getting Started

5.1 Preparation



Biohazard: Always wear appropriate gloves, masks and safety goggles during and after any biohazardous operations and during the extraction process, even when touching the device, since the device can become contaminated.

IMPORTANT!

Before the extraction, wear appropriate gloves, mask and safety goggles if required by the operation. Be careful not to contaminate the sample material with sweat, saliva, etc., during the sample preparation steps and closely follow the extraction kit instructions.

5.2 Operation with the foodproof® Magnetic Preparation Kit VI (KIT230184)

5.2.1 Procedure

1. Start the machine and select 'Run Prog.' (top left), then select the pre-installed program 'MPKVI' using the shortcut.



Caution: Do not select 'Run' before loading the machine; otherwise, the robot will start operating without plates in place.

2. Load Plates
 - a. Select 'View' and the symbol for the rotary table to display which plates ('Name') are in which position ('Plate') of the rotary table.
 - b. Insert plates into positions 1, 2, 3, 4, 5 and 8. (Positions 6 and 7 should remain vacant.)

Notes:

- To turn the rotary table to the appropriate position, press one of the two buttons in front of the sliding transparent cover or select the plate number on the touchscreen.
- Avoid splashing liquid when putting the plates into position.

Plate 'Name'	Rotary Table Position 'Plate' Number	Description
- Load -	1	Plate with Tip Comb
LyBi	2	Lysis Plate
Wash 1	3	Wash Plate 1
Wash 2	4	Wash Plate 2
Wash 3	5	Wash Plate 3
Dry/Elution	8	Elution Plate

3. Start the program by selecting 'Run' on the touchscreen.

Notes:

- All extraction steps will run automatically.
- At the end of the extraction protocol, the elution plate (Position 8) will contain the extracted viral RNA or DNA.

5.2.1 Visual Representation of Procedure Steps



1. Select pre-installed program 'MPKV1.'



2. Select 'View' to see plate positioning.



3. View plate positioning in table and graphic.

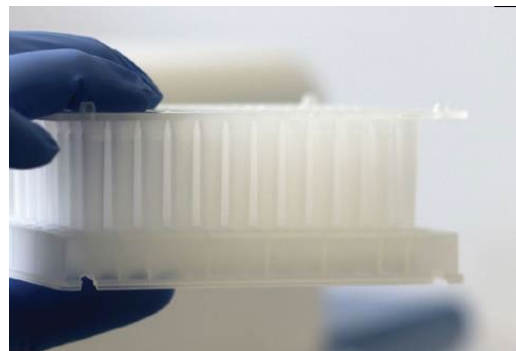

4. Place the Tip Comb on an Elution Plate.

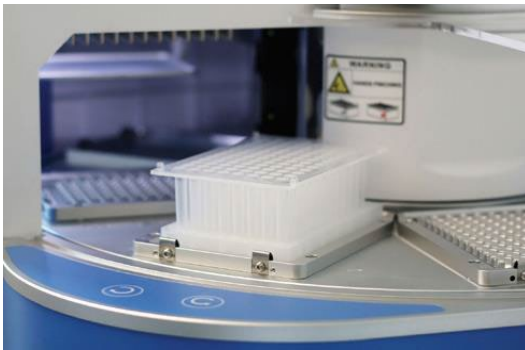

5. Insert the Plate-Tip Comb into position 1.

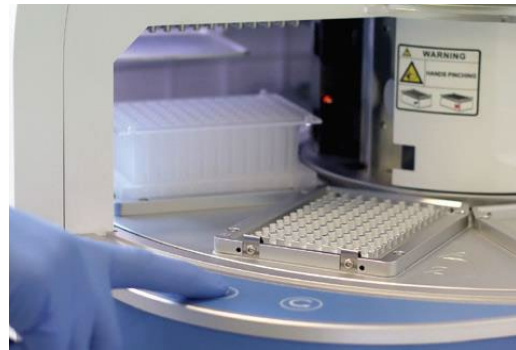

6. Press 1 of 2 buttons to rotate to other positions.

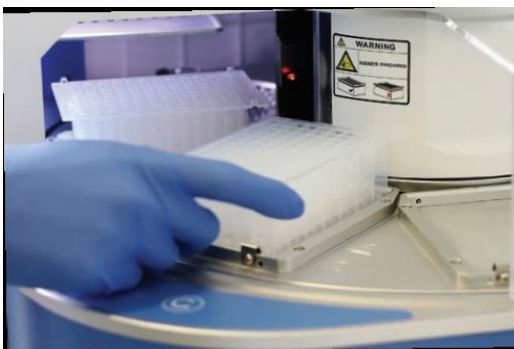

7. Insert plates in the specified order.

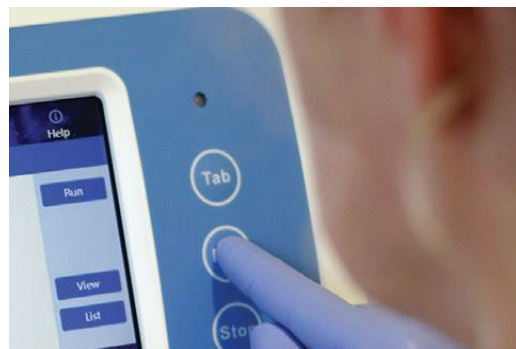

8. Select 'Run' to start the program.

6. Cleaning and Maintenance

6.1 Cleaning the RoboPrep 96

- After each run, remove used plastic consumables.
- At the end of each day, remove any fluid from the inside and outside of the instrument using a damp cloth moistened with 70% ethanol, then disinfect the inside with UV light.
Select the 'UV Sterilizer' button and set the disinfection time.
- Gently clean the instrument body by removing dust with a dry, soft cloth. If the outside is heavily soiled or contaminated with potentially infectious material, clean the instrument using a soft paper tissue wet with either a 0.5% sodium hypochlorite solution or 70% ethanol.

6.2 RoboPrep 96 Maintenance

Two types of maintenance must be performed on the RoboPrep 96 instrument as described in the following table:

Maintenance Type	Performed by	Schedule
Routine cleaning of the instrument body <ul style="list-style-type: none"> • Outside • Inside 	<ul style="list-style-type: none"> • User • User 	<ul style="list-style-type: none"> • Weekly • Daily
Preventive	<ul style="list-style-type: none"> • Service engineer 	<ul style="list-style-type: none"> • Annually

 Maintenance
<ul style="list-style-type: none"> • The instrument should be cleaned regularly using a soft, damp cloth with a small amount of alcohol. If there are stains on the instrument's surface, wipe it with a soft, damp cloth containing a cleansing reagent. • At the end of the run, to avoid any reagent contamination, carefully remove the disposables containing prepared reactions or remaining reagents and ensure that each reagent tube is closed using the correct caps. • To ensure the correct use of all reagents, always check the expiration date, required preparation, stability and the need for cooling blocks before use. It is the user's responsibility to ensure that all reagents are completely dissolved and homogeneous for accurate pipetting. For more information, refer to the instructions for the use of the reagents.



7. Troubleshooting

Problem	Cause	Solution
No display after the power switch was turned on	Power disconnected	Check the AC power cord connections at both ends. Ensure that the correct cords are in use.
	Blown fuse	Replace the fuse (5 x 20 250V 8A).
	Malfunctioning power switch	Replace the switch.
	Other	Contact your local representative.
No UV light	UV light failure	Replace the light tube. Contact your local representative.
No light	Light failure	Replace the light tube. Contact your local representative.
Does not stop automatically after opening the doors	Sensor failure	Contact your local representative.
Large variance between actual and display temperature	Sensor failure	Contact your local representative.
No heating	Sensor or heater failure	Contact your local representative.
Instrument does not run	Controller or motor failure	Contact your local representative.
Abnormal sounds during operation	Guide rail installed incorrectly	Contact your local representative.
	Motor failure	
	Synchronous belt abrasion	
'Press' button not working	'Press' button failure	Contact your local representative.

8. Software Error Alarm List

If you observe one of the following error messages, contact technical support at www.hygiena.com/support:

Fault Type	Fault Name	Error
Temperature (code: 0)	T1 Overheat	E011
	T1 Open circuit	E015
	T1 Short circuit	E016
Electric machinery stroke position (code:4)	Baffle motor sensor damaged	E404
	Rotary motor sensor damaged	E405
	Lifting platform motor sensor damaged	E406
	Push rod motor sensor damaged	E407
	Motor position sensor of magnetic rod sleeve damaged	E425
	Magnetic rod motor position sensor damaged	E415



Fault Type	Fault Name	Error
LCD, Crystal oscillator, Storage (code: 7)	The clock crystal fault	E702
	Memory chip E2P damaged Setting parameters lost	E703
	New instrument: instrument type is not set	
	Zero has not been calibrated: if the instrument zero calibration is not in the 3rd well, the program will not work	
Communication (code: 8)	Moving parts online failure	E801
	Rotary parts online failure	E802

9. Tags

The following marks appear on the instrument:

Mark	Description
	Warning label
	Heating label
	Conformite Europeenne
	Be careful of hands

10. Supplementary Information

10.1 Liability

WARRANTY AND DISCLAIMER OF LIABILITY

Limited Warranty and Disclaimer of Liability. Hygiena Diagnostics GmbH warrants that this product is free from defects in materials and workmanship for 12 months and only if the following are complied with:

- (1) The product is used according to the guidelines and instructions set forth in the product literature.
- (2) Hygiena Diagnostics GmbH does not warrant its product against any and all defects when: the defect is as a result of material or workmanship not provided by Hygiena Diagnostics GmbH; defects caused by misuse or use contrary to the instructions supplied, or if the product is contaminated by improper storage or handling.
- (3) All warranties of merchantability and fitness for a particular purpose, written, oral, expressed or implied, shall extend only for a period of one year from the date of manufacture. There are no other warranties that extend beyond those described on the face of this warranty.



(4) Hygiena Diagnostics GmbH does not undertake responsibility to any purchaser of its product for any undertaking, representation or warranty made by any dealers or distributors selling its products beyond those herein unless expressed in writing by an officer of Hygiena Diagnostics GmbH.

(5) Hygiena Diagnostics GmbH does not assume responsibility for incidental or consequential damages, including, but not limited to responsibility for loss of use of this product, removal or replacement labor, loss of time, inconvenience, expense for telephone calls, shipping expenses, loss or damage to property or loss of revenue, personal injuries or wrongful death.

(6) Hygiena Diagnostics GmbH reserves the right to replace or allow credit for any modules returned under this warranty.

10.2 Trademarks

foodproof®, **microproof®**, **vetproof®**, **ShortPrep®**, **StarPrep®**, **RoboPrep®** and **LyoKit®** are registered trademarks of Hygiena Diagnostics GmbH. **Hygiena®** is a registered trademark of Hygiena. Other brand or product names are trademarks of their respective holders.

10.3 Copyrights

All rights reserved. No parts of this work may be reproduced in any form or by any means—graphic, electronic or mechanical, including photocopying, recording, taping or information storage and retrieval systems without the written permission of the authors.

10.4 Contact and Support

If you have questions about this or any other Hygiena Diagnostics product, contact our Technical Support staff (www.hygiena.com/support). Our commitment is to provide our customers with rapid and effective assistance. Contact us if you have suggestions for enhancing our product performance or using our products in new or specialized ways. Such customer information has repeatedly proven invaluable to us and the worldwide research community.

10.5 Reference Number

The reference number and original Hygiena Diagnostics GmbH article number: D 210 50 22.

11. Change Index

Version 1, August 2021:

First version of the operation manual.

Revision A, October 2024:

Rebranding and new layout.

D 210 50 22 -> INS-MCH230001-REVA.

Hygiena[®]
Camarillo, CA 93012
USA
diagnostics.support@hygiena.com

Manufactured for
Hygiena Diagnostics GmbH
Hermannswerder 17
14473 Potsdam
Germany
www.hygiena.com